

CARMEN

Twin-lever basin mixer with smooth body and swivel spout. L-Size

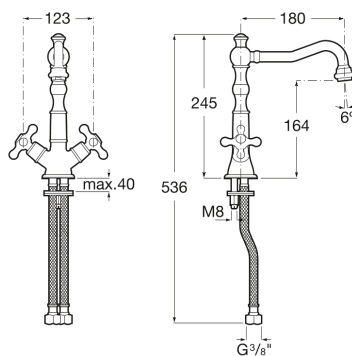

TECHNICAL DRAWINGS



FEATURES

Twin-lever basin mixer with smooth body, swivel spout, click-clack waste and flexible supply hoses. L-Size

Annual energy consumption (kWh/p.a.): 301.21

Application place: Basin

Faucet type: Twin-lever

Flow rate (l/min - 3 bar): 4.5

Installation type: Deck-mounted

Waste type: Click-clack waste



Carmen

Carmen is a tribute to one of Roca's most iconic basins of the 1940s, which comes back with a clear vintage character to become a vitreous china and furniture collection with the latest innovations in the design of bathroom spaces.



INSTALLATION AND USER MANUALS



[Installation Handbook](#)